

THIS DRAWING IS UNPUBLISHED. RELEASED FOR PUBLICATION
 © COPYRIGHT - By - ALL RIGHTS RESERVED.

LOC	DIST	REVISIONS					
GP	00	P	LTR	DESCRIPTION	DATE	DWN	APVD
		A		INITIAL RELEASE	07JUL2015	MY	GG

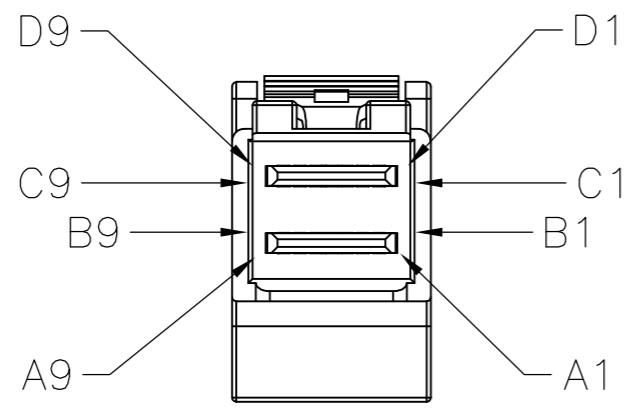
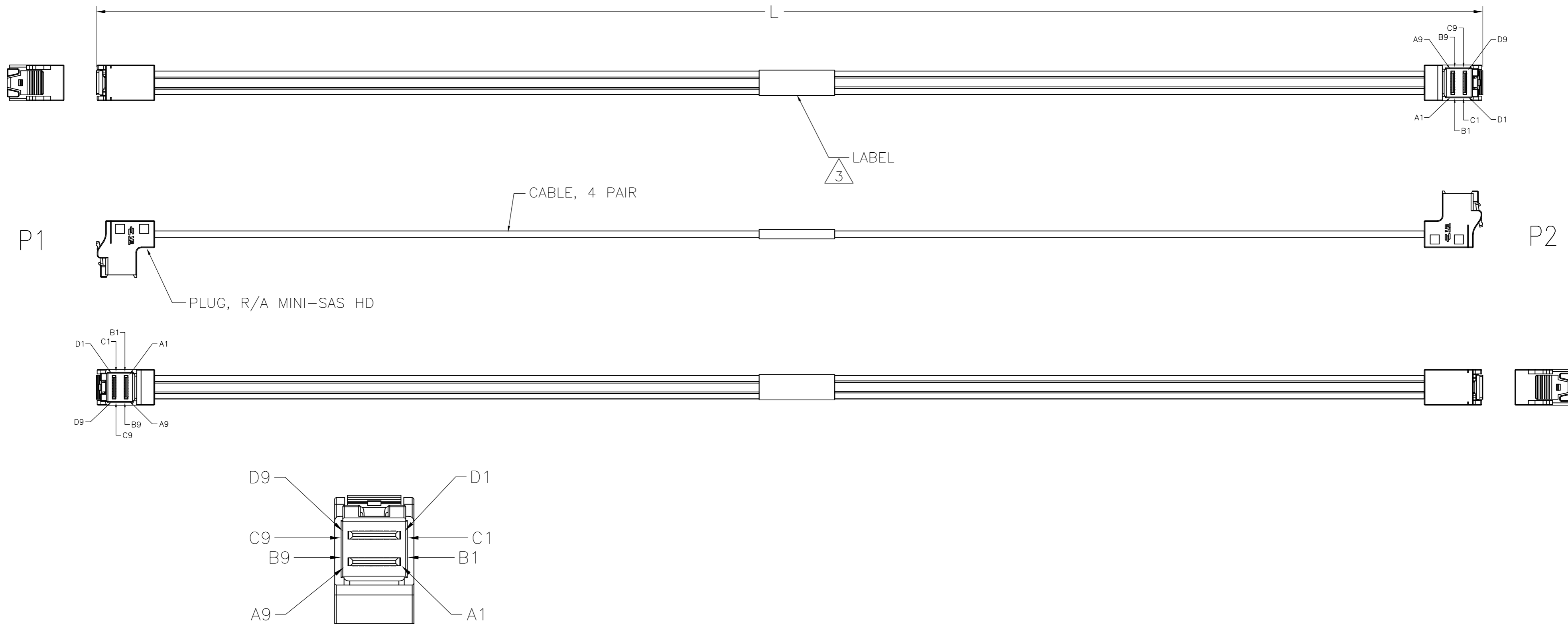

1. ASSEMBLY TO BE 100% TESTED FOR CONTINUITY, SHORTS, AND OPENS, CABLES ASSEMBLYS ARE ALSO TO BE 100% TESTED FOR SIGNAL INTEGRITY, TO SAS 3.0 REQUIREMENTS.

2. ROHS AND REACH COMPLIANCE: PRODUCT AND PROCESSING MEETS REQUIREMENTS OF TE SPECIFICATION TEC-138-702.

3. LABEL CENTERED AND LABEL INFORMATION AS BELOW:

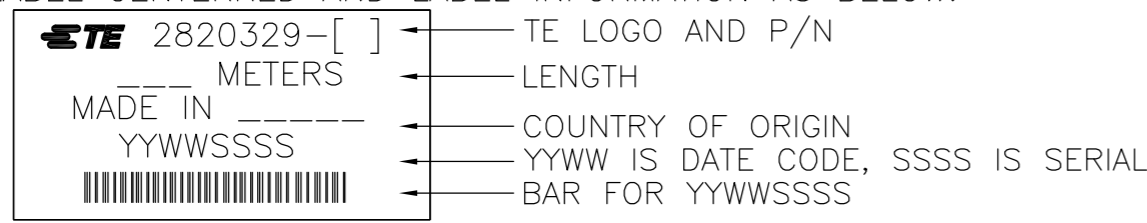

4. SEE SHEET #2 FOR WIRING SCHEMATIC.

1000	+25 -0	2820329-4
700	+25 -0	2820329-3
500	+25 -0	2820329-2
300	+25 -0	2820329-1
"L"[MM]		TE P/N

THIS DRAWING IS A CONTROLLED DOCUMENT.		DWN	16/JUN/2014	 TE Connectivity	NAME C/A, INTERNAL HD MINI SAS, R/A TO R/A 100 OHMS, 4X, NON HALOGEN		
DIMENSIONS:		CHK	16/JUN/2014				
mm	TOLERANCES UNLESS OTHERWISE SPECIFIED:	APVD	16/JUN/2014				
	0 PLC ± -	PRODUCT SPEC					
	1 PLC ± -	APPLICATION SPEC		SIZE	CAGE CODE	DRAWING NO	RESTRICTED TO
	2 PLC ± -			A2	00779	C=2820329	
	3 PLC ± -			CUSTOMER DRAWING			SCALE
	4 PLC ± -						N.T.S.
	ANGLES ± -						SHEET
MATERIAL	FINISH	WEIGHT					1 of 2
							REV
							A

THIS DRAWING IS UNPUBLISHED. RELEASED FOR PUBLICATION
 © COPYRIGHT - By - ALL RIGHTS RESERVED.

LOC		DIST		REVISIONS			
P	LTR	DESCRIPTION	DATE	DWN	APVD		
GP	00	-	SEE SHEET 1	-	-		

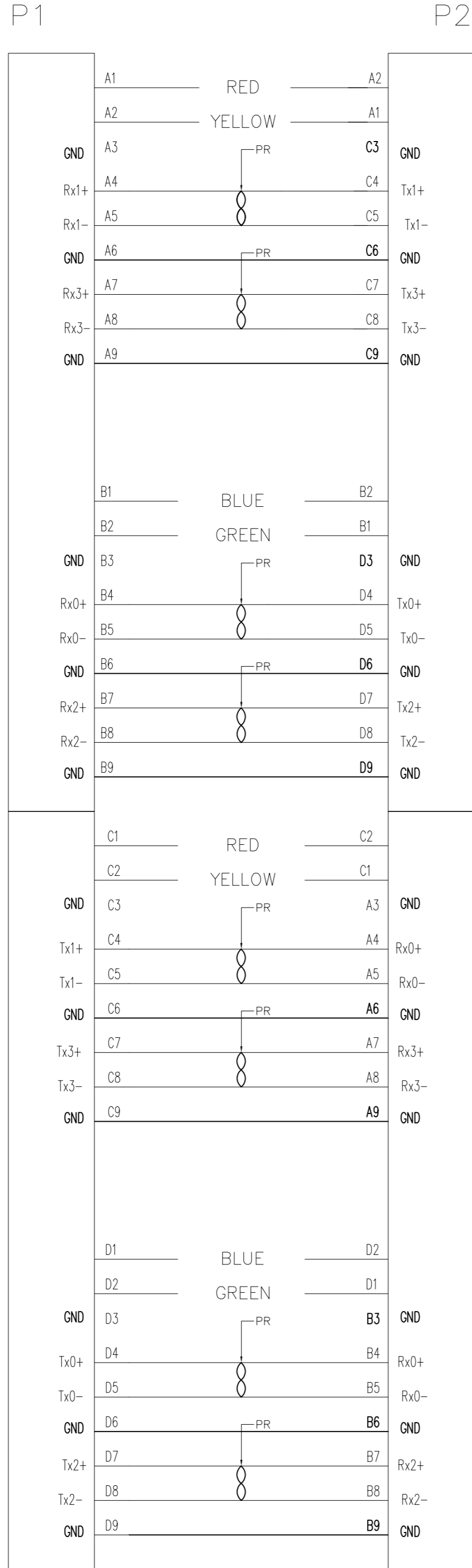

WIRING PATTERN

THIS DRAWING IS A CONTROLLED DOCUMENT.		DWN	16/JUN/2014	 TE Connectivity
DIMENSIONS: mm		CHK	16/JUN/2014	
TOLERANCES UNLESS OTHERWISE SPECIFIED:		APVD	16/JUN/2014	
0 PLC ± - 1 PLC ± - 2 PLC ± - 3 PLC ± - 4 PLC ± - ANGLES ± -		PRODUCT SPEC	NAME	
MATERIAL		G.GUTGOLD		C/A, INTERNAL HD MINI SAS, R/A TO R/A 100 OHMS, 4X, NON HALOGEN
FINISH		G.GUTGOLD		SIZE A2
WEIGHT		-		CAGE CODE 00779
CUSTOMER DRAWING		-		DRAWING NO. C=2820329
SCALE N.T.S.		SHEET 2 OF 2		RESTRICTED TO
REV A				