

COUNT	DESCRIPTION OF REVISIONS	BY	CHKD	DATE	COUNT	DESCRIPTION OF REVISIONS	BY	CHKD	DATE
△					△				
△					△				
△					△				

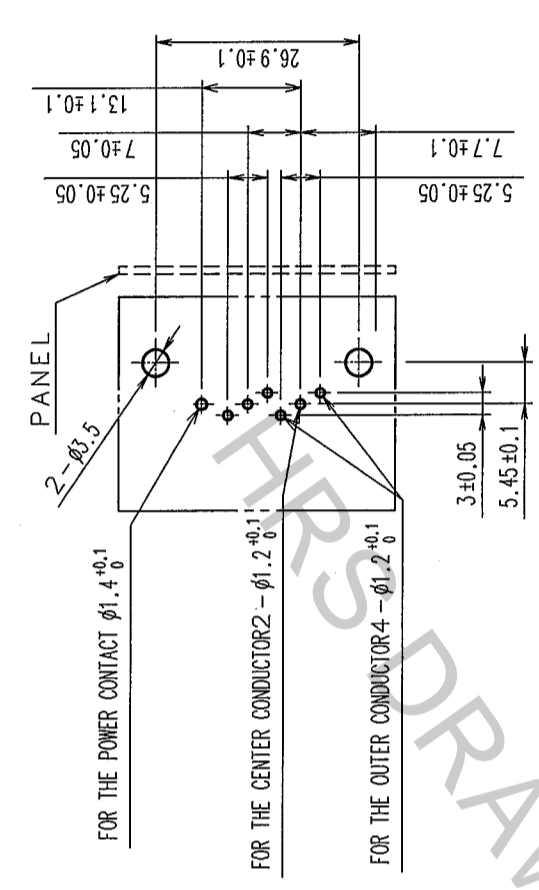

RECOMMENDED PC BOARD HOLE PATTERN

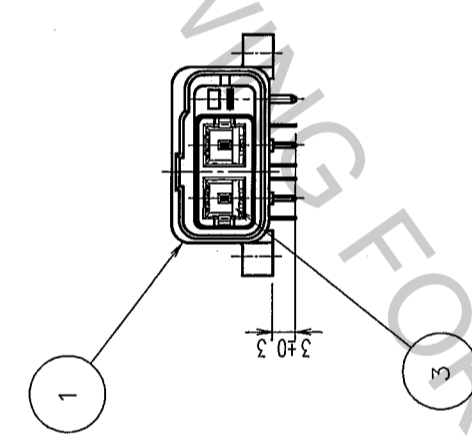
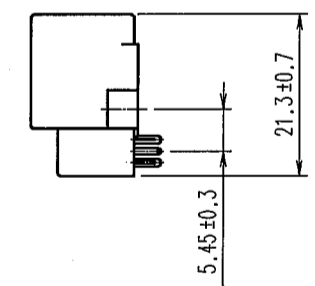
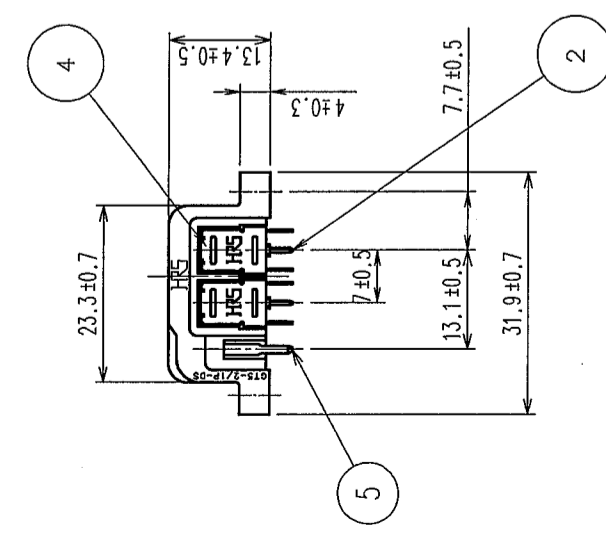
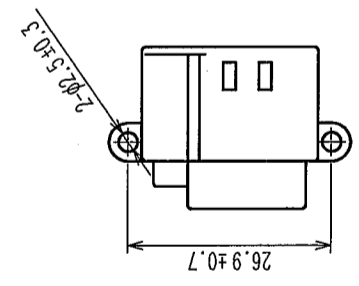
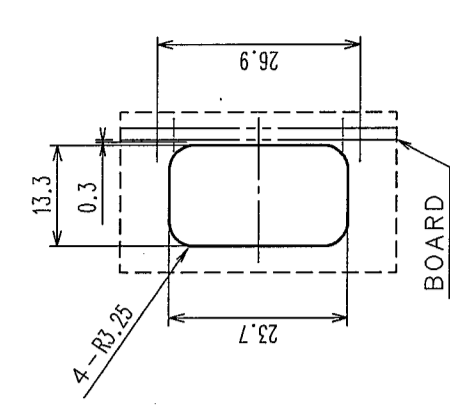

RECOMMENDED PANEL CUTOUT

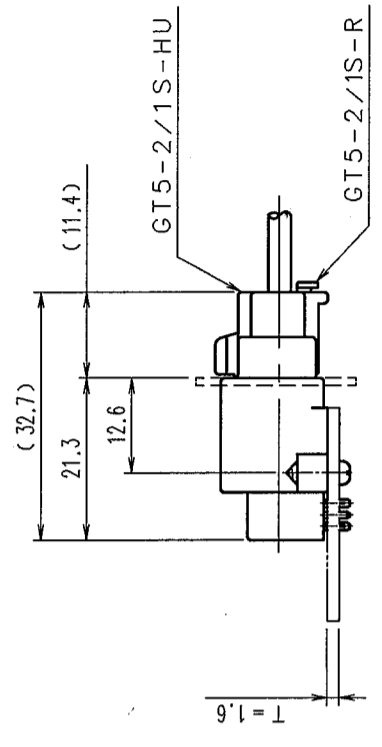

MATED CONNECTORS

Pb FREE

NOTE1. DEPENDING ON THE CIRCUMSTANCES, RECESS OF WELDING SHALL BE ADDED TO MOLD TO PREVENT SINKAGE.
 2. FIXING SCREW SHALL BE IN ACCORDANCE WITH ISO 1481 AND 7049, NOMINAL DIAMETER 3.

NO.	MATERIAL	FINISH, REMARKS	NO.	MATERIAL	FINISH, REMARKS
2	BRASS	TIN PLATED	5	BRASS	TIN PLATED
1	PBT	UL94V-0	4	PHOSPHOR BRONZE	TIN PLATED
			3	PBT	UL94V-0 DARK GRAY

CODE NO. (OLD)	DESIGNED	CHECKED	APPROVED	RELEASED
	S. KURIYA	K. Aoto	K. Aoto	
	05.4.27	92.6.10	05.4.28	05.4.28

DRAWING NO.	PART NO.
EDC3-071716-01	GT5-2/1P-DS(70)

SCALE	UNITS	CODE NO.
1 : 1	mm	CL755-0014-0-70