

THIS DRAWING IS UNPUBLISHED. RELEASED FOR PUBLICATION
 © COPYRIGHT - By - ALL RIGHTS RESERVED.

REVISIONS				
P	LTR	DESCRIPTION	DATE	APVD
A3		REVISED PER ECR-17-008705	15NOV2017	FV SK

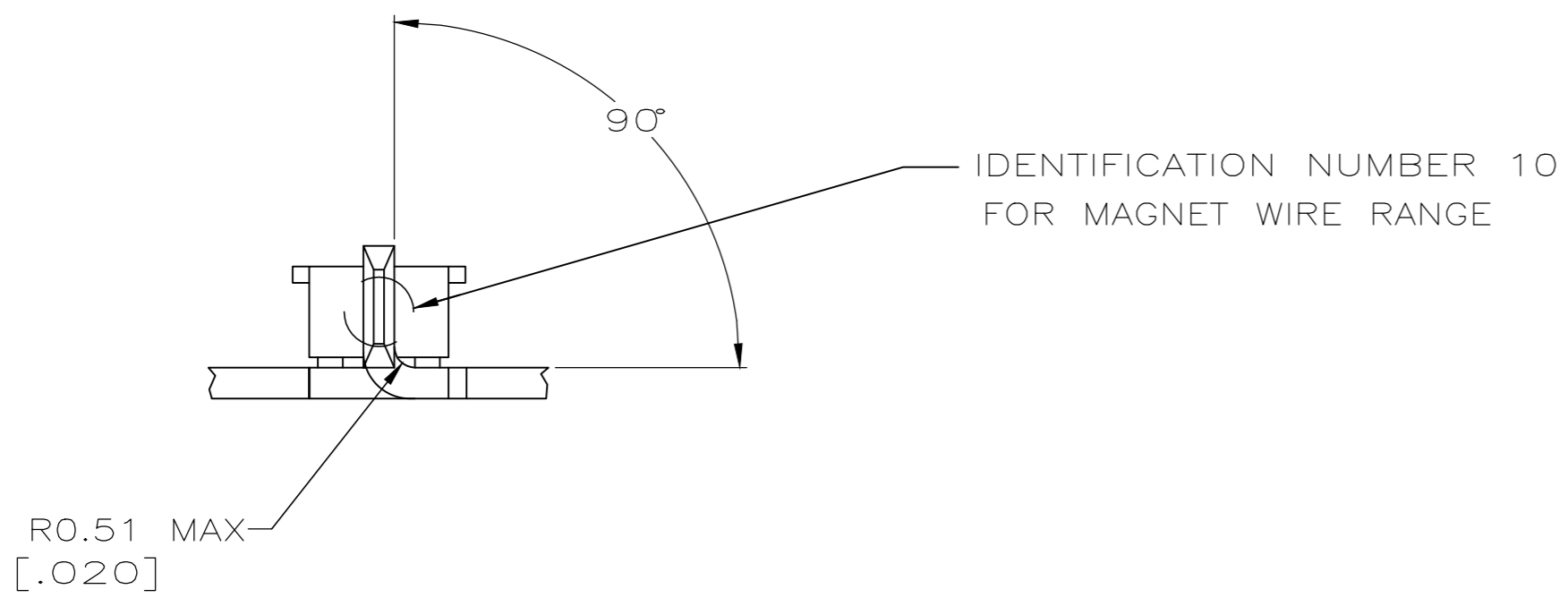

- 1 CONTINUOUS STRIP ON REELS WITH TERMINALS LOCATED ON 8.38±0.076 [.330±.003] CENTERS
- 2 SLOT ACCEPTS 0.36-0.57 [#27-#23 AWG] SINGLE OR DOUBLE COPPER MAGNET WIRE ONLY
 SLOT ACCEPTS 0.51-0.64 [#24-#22 AWG] SINGLE OR DOUBLE ALUMINUM MAGNET WIRE ONLY
- 3 REFER TO DWG 87-1039-3 FOR ADDITIONAL CAVITY INFORMATION (MODIFIED DEPTH)
- 4 0.0010 [.000040] MIN TIN PLATE

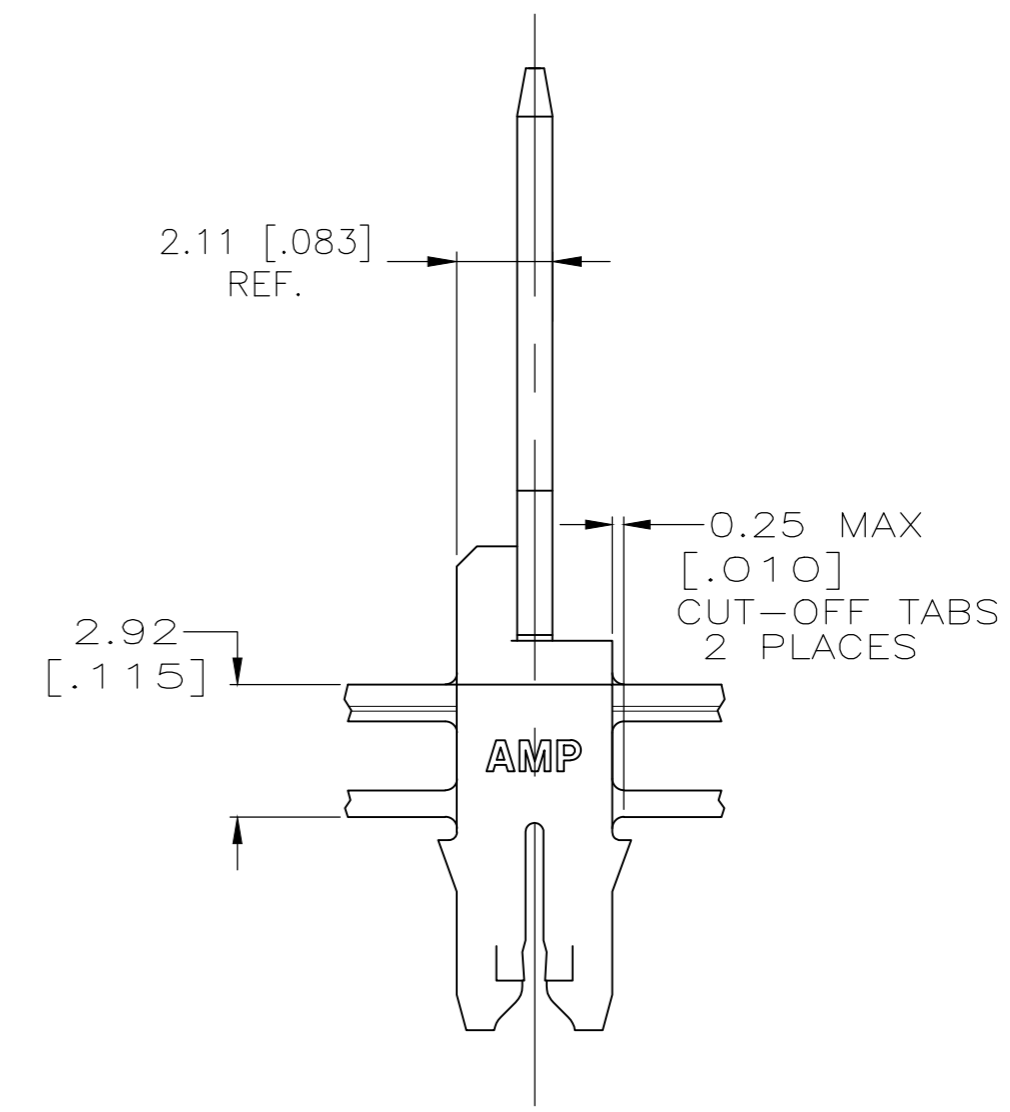
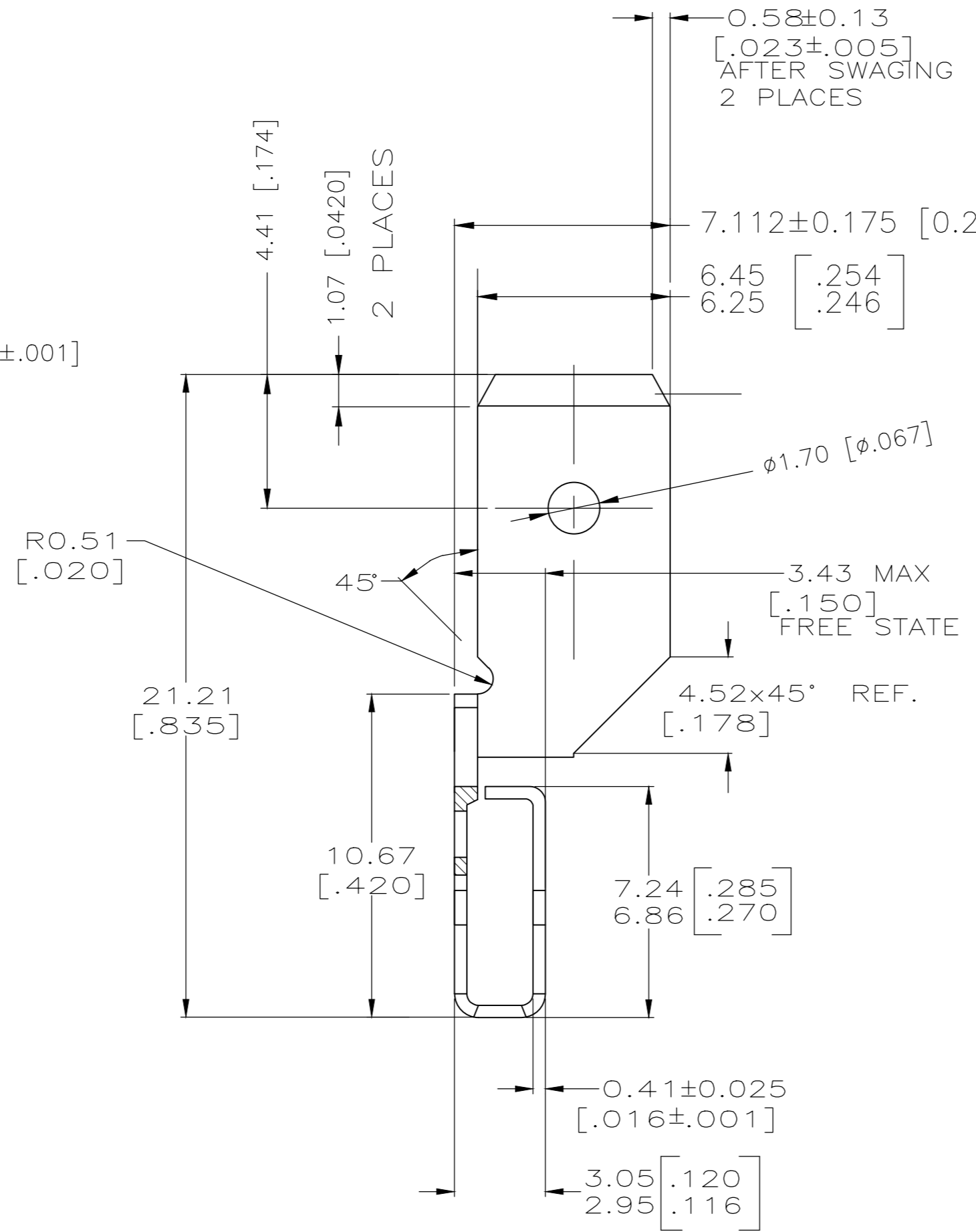
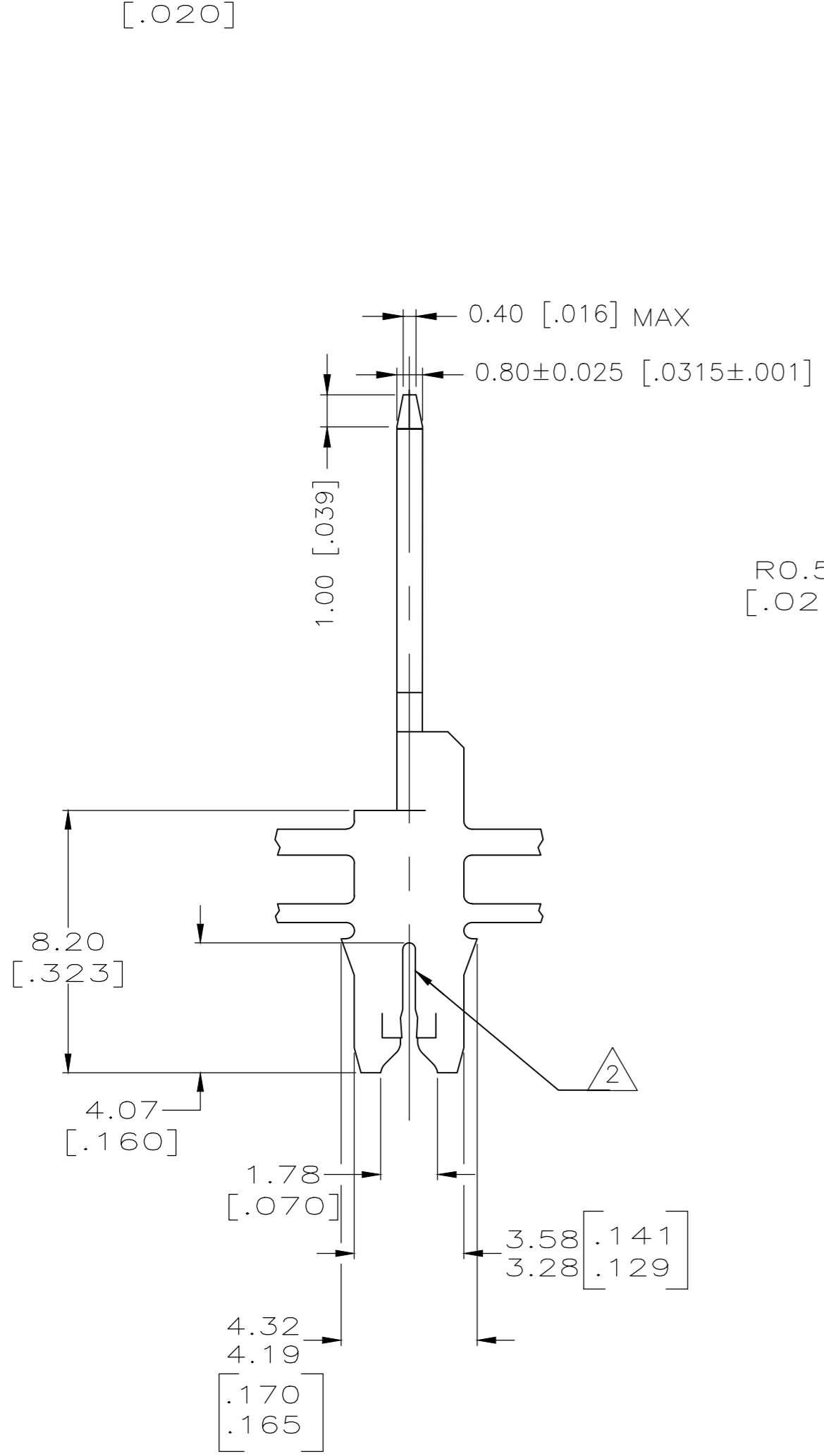

THIS DRAWING IS A CONTROLLED DOCUMENT.		DWN R.GRZYBOWSKI 24JUN97	4 FINISH WELD 2232555-1	
DIMENSIONS: mm		CHK M.S.FEHER 24JUN97	SPLICE PART NUMBER	
TOLERANCES UNLESS OTHERWISE SPECIFIED:		APVD N.E.NEFF 24JUN97	TE Connectivity	
0 PLC ± -	1 PLC ± -	NAME	TAB, 6.30 [.250] CONNECTING, MAG-MATE	
2 PLC ± 0.25 [.010]	3 PLC ± -	PRODUCT SPEC	-	
4 PLC ± -	ANGLES ± 5°	APPLICATION SPEC	SIZE A2	CAGE CODE 00779
MATERIAL PRE-MILLED BRASS	FINISH SEE TABLE	108-2012	DRAWING NO C=2232555	RESTRICTED TO -
		114-2046	SCALE 6:1	SHEET 1 of 1
		WEIGHT 0.000000	REV A3	
		CUSTOMER DRAWING		